

The exhibition covering all fields  
of new sensing technologies

# SENSOR

## EXPO JAPAN 2024

Exhibition  
Guideline

9. 18<sup>WED</sup> ▶ 20<sup>FRI</sup> 10:00 - 17:00  
Tokyo Big Sight, East Hall

 産経新聞社

SANKEI SHIMBUN CO., LTD.

"SENSOR EXPO JAPAN" Show Office

1-7-2 Otemachi, Chiyoda-ku, Tokyo 100-8079, Japan

TEL: +81-3-3273-6180 FAX: +81-3-3241-4999 E-mail: sensor@sankei.co.jp

[www.sensorexpojapan.com](http://www.sensorexpojapan.com)

# Exhibition Outline

**Exhibition Name:** SENSOR EXPO JAPAN 2024

**Dates:** September 18 (Wed) - 20 (Fri), 2024

**Venue:** Tokyo Big Sight (Tokyo, Japan), East Hall

**Organizer:** SANKEI SHIMBUN CO., LTD.

**Special Partner:** Japan Society of Next Generation Sensor Technology

Supporting and cooperate organizations will be listed on our website once determined.

# Exhibition Subjects

## SENSOR EXPO JAPAN 2024

The exhibition covering all fields of new sensing technologies. This show regroups products and applications for sensors, controls, systems, devices, technologies and information.

### Regrouping

- Sensors ■ Micromachines ■ Actuators ■ Control, measurement, test, inspection field-related machines, devices and systems
- Components, materials ■ Electric power, energy ■ Biotechnology ■ Nanotechnology ■ Robots ■ Imaging devices, Cameras ■ Software
- Other engineered products and information ■ IoT, MEMS·NEMS

# Visitors Categories

- Developers and engineers looking for advanced sensing technologies
- Specialists involved in design, manufacture, quality control and inspection, procurement
- Actors from various industries - retail, trade, service, fisheries, forest and agriculture, public infrastructure (transport, communication, energy, etc.) - medical institutions or governmental agencies considering the use of innovative sensors.

### Concurrent Exhibitions

■ JIMA 2024	Organizer : General Incorporated Association Japan Inspection Instruments Manufacturers' Association
■ IFPEX 2024	Organizer : Japan Fluid Power Association / SANKEI SHIMBUN CO., LTD
■ INTERMEASURE 2024	Organizer : Japan Measuring Instruments Federation (JMIF)
■ Geotechnical Forum 2024	Organizer : GEPC / SANKEI SHIMBUN CO., LTD.
■ FORESTRISE 2024	Organizer : SANKEI SHIMBUN CO., LTD.
■ FORESTROPOLITAN 2024	Organizer : SANKEI SHIMBUN CO., LTD.

# Schedule

## Schedule until the exhibition (2024)

<b>April 30 (Tue)</b> Deadline for Application (sending invoice after receiving the Application Form)	<b>July</b> ① Sending Exhibitor Manual, Floorplan and other exhibiting material ② Promotional Activities (web banner, exhibitors' details)	<b>September 16 (Mon)</b> 9:00 - 18:00 Booth construction, Exhibitors Move-in	<b>September</b> <b>17 (Tue)</b> 9:00 - 18:00 Exhibitors Move-in <b>18 (Wed)</b> 10:00 - 17:00 Exhibition Period <b>19 (Thu)</b> 10:00 - 17:00 Exhibition Period <b>20 (Fri)</b> 10:00 - 17:00 Exhibition Period, Moving-out from 17:00	<b>End of December</b> Exhibition Report
--	--	---	---	---

# Sensor Expo Japan 2024 Exhibition & Forum

## Overall Structure

### ◆ Exhibition

Booth exhibits will be provided by leading companies and organizations involved in sensing and elemental technologies.

Exhibitors will promote the latest products, technologies, services, peripherals, and other information that contributes to the AI and IoT society.

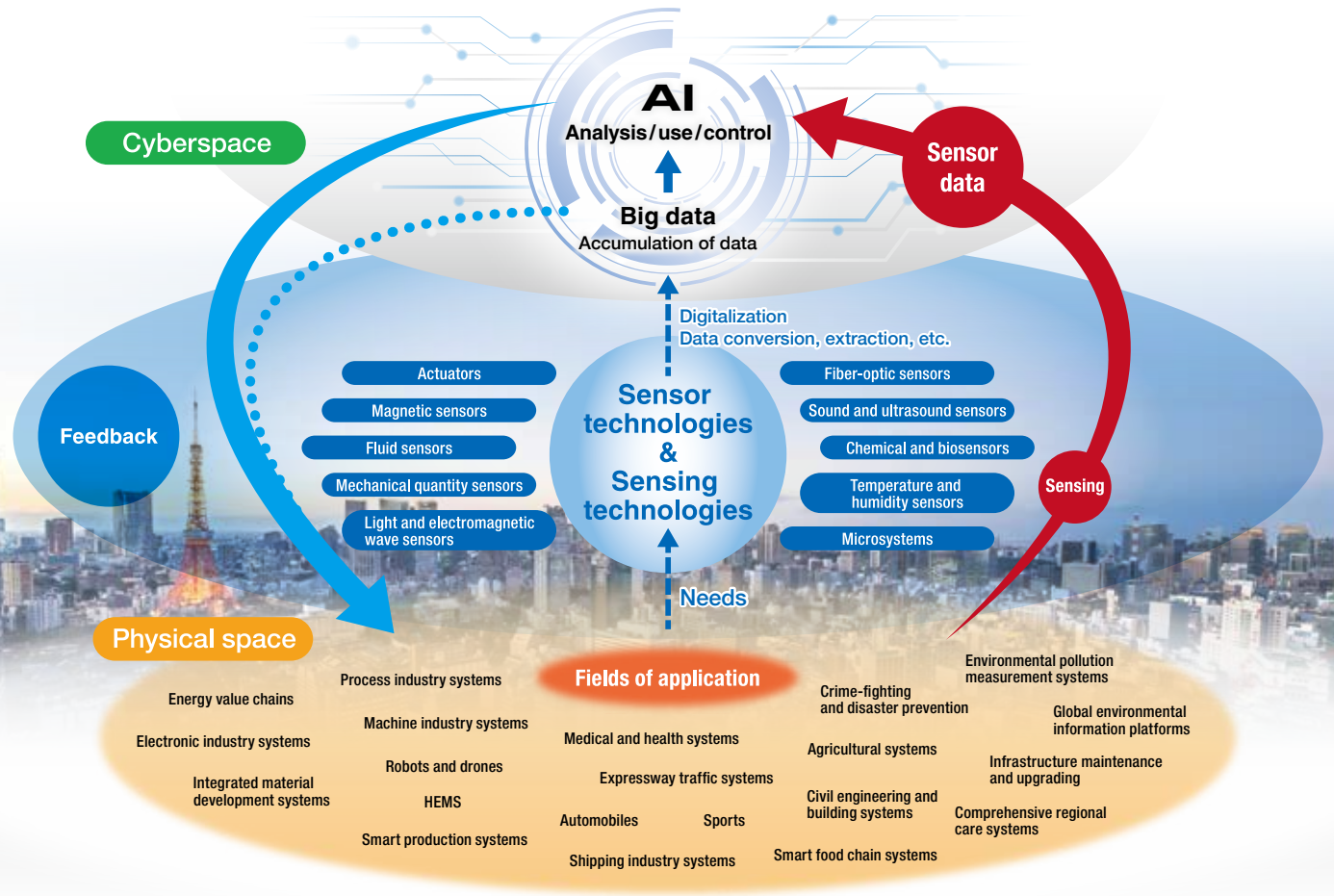

## Sensors and Technologies

This zone will exhibit technologies and products including sensors and electronic components and devices, as well as technologies such as AI and software.

### We welcome exhibits of the following types:

- ① Electronic components, devices, modules, etc. exhibited by application.
- ② Exhibits focusing on specific elemental technologies.
- ③ Devices and technologies for which target applications have not yet been identified.

### Target exhibitors

- All companies and organizations capable of exhibiting products and technologies in the exhibition categories.

### Exhibition categories

#### Sensors

- Light and electromagnetic wave (Photosensors, infrared sensors, radiation sensors, ultraviolet sensors, laser sensors, photoelectric sensors, fiber-optic sensors, illuminance sensors, photodiodes, etc.)
- Mechanical and physical quantity (Pressure sensors, accelerometers, angular rate sensors, rotation sensors, displacement sensors, impact sensors, strain sensors, motion sensors, torque sensors, etc.)
- Temperature, humidity, and fluid (Temperature sensors, humidity sensors, heat flux sensors, flow sensors, level sensors, density sensors, etc.)
- Magnetic and current (Magnetic sensors, current sensors, etc.)
- Chemistry and biotechnology (Gas sensors, ion sensors, odor sensors, taste sensors, etc.)
- Biometric (Brain wave sensors, pulse wave sensors, etc.)
- Image (Image sensing technologies, smart sensors, remote sensing technologies, etc.)
- Environmental (Particle sensors, pollen sensors, etc.)
- Sound and ultrasound ● Touch ● RFID ● Bar code readers/OCR
- Sensor fusion ● Micromachine, MEMS, NEMS ● Actuators ● Sensor network systems and technologies
- Sensor components, parts, and materials ● Measurement, control, testing, and inspection devices, equipment, and systems
- Electronic equipment
- Communication devices and networks (RFID, NFC, Bluetooth Beacon, Zigbee, Wi-SUN, LPWA, Wi-Fi, 5G, LTE, etc.)
- Software (AI, data analysis, data processing algorithm development, control, image processing, etc.)
- Electromagnetic, EMC, noise suppression ● Battery and power supply ● Other

## Visitors profile

- R&D staff, engineers, and marketing personnel from a wide range of industries requiring sensors and sensing technologies
- Specialists and staff in fields including design, manufacturing, production, quality control and testing, procurement and materials, etc.
- All those seeking to investigate or gather information on the use of new sensors, including healthcare and government personnel and social infrastructure providers in fields such as distribution, service industries, retail, agriculture, forestry, fisheries, transportation, communications, and energy
- Persons responsible for promoting IoT introduction in a wide range of industries
- Trading companies ● Industry organizations ● Academic, research, and development organizations ● Government agencies ● Consultants ● Students

# Booth Specifications and Exhibition Fee

## A Type Booth

### Booth specifications

1 booth (width 2.97m × depth 2.97m • center to center)  
rear and side walls only (except for corner booth)

\*Decorations, Name Box, Carpeting, etc. are not included.

### Exhibition fee

**One booth 429,000 yen** (\*including tax)

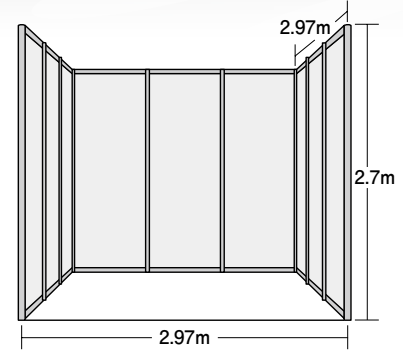

### Layout of booths

You can select any floor pattern from those below according to the number of modular panels you wish to use.

Number of booths	Booth Types and Decoration Height Limitations	Booth Arrangement
1-3 booth(s):	Row type only (height: up to 2.7m *up to 4m when set back 1m)	
4-5 booths	Choice of row type or block type (height: up to 4m) *An Island booth is surrounded by aisles on all sides. For a Row Type, please contact the show office.	
6 or more booths	Island booth only (height: up to 5m) *Four sides are opened. If you wish to have the row type, please contact the management office. *An Island booth is surrounded by aisles on all sides. For a Row Type, please contact the show office.	

## Display Package\*

### Proposed Ready-to-move-in Display Package

► **One booth Type (3x3m) Exhibition Fee + 121,000 yen** (\*including tax)

System Wall Panel (Octanorm system) / Company name / Carpet

Option Items : Reception Counter (W900 × D450 × H800) ×1

Electricity : LED Fluorescent 20W × 1 / LED Spotlights 15W × 2 / Electrical outlet × 2 (100V with ground) / Wiring cost and Electric rates × 1kW

Rental Furniture : Folding Chair×1 / Name Box × 1



## B Type Booth Up to 2 booth per company

### Booth specifications

1 booth (width 1.98m × depth 1.98m • center to center)

\*Decorations and furniture included

### Exhibition fee

**One unique booth 253,000 yen** (\*including tax)

**Included in the exhibition fee :** Exhibition space / Rear and 1m side walls / Company nameplate / Carpet / Exhibition stand (W990 × D990 × H750) / Slide door unit (without key) / LED spotlight 15W × 1 / Electrical outlet × 2 (100V with ground) / Wiring cost and Electric rates × 500W

※ Additional equipment is submitted to additional charges. Details of available equipment will be sent in August (planned) (Exhibitor Manual).

\* No deductions can be made even when the basic display mentioned above is not used.

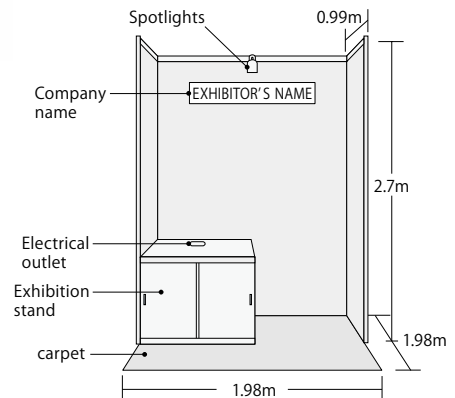

### Booth layout and height limit

Exhibitors can decorate the booths to a height of 2.7m.

## Web Banner

### Highlight your presence beforehand with a Link Banner on Sensor Expo Japan Official Website

**Period of availability:** From August 7 to September 20, 2024

**Banner size:** W200px × H40px GIF format (can be animated)

**Publication Fee:** **55,000 yen** (\*including tax)

**Material due date:** July 24, 2024 ※ for final version data at the above size